

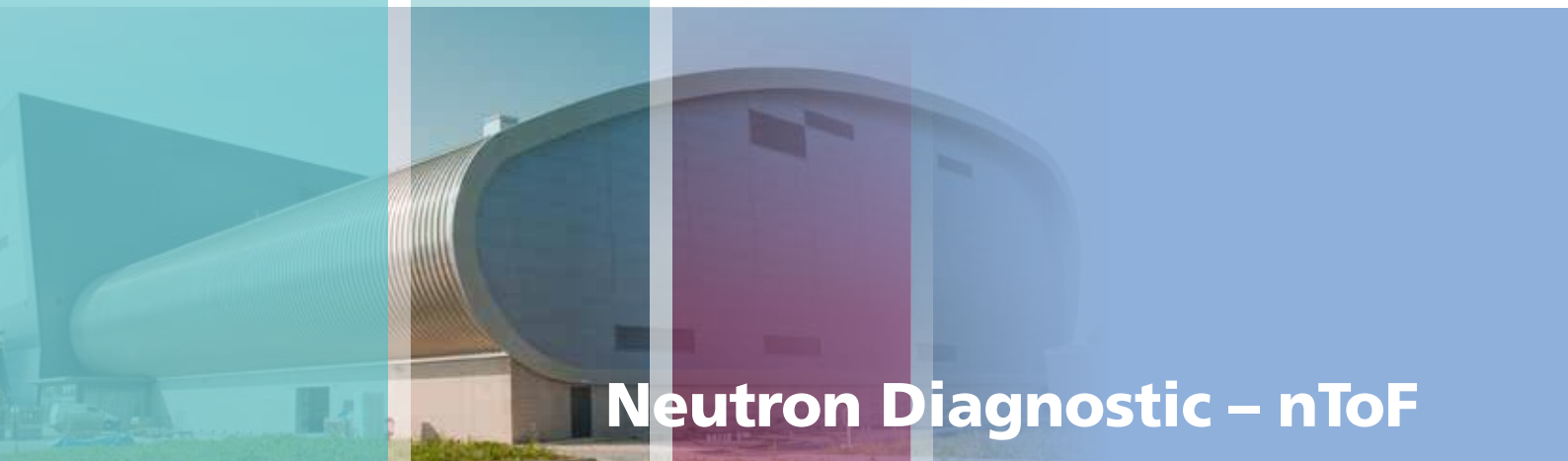

Orion: Target diagnostic



Neutron Diagnostic – nToF

The Orion laser facility at AWE Aldermaston, one of the largest scientific capital investments in the UK, houses a large neodymium glass laser system and a target chamber in which the high energy density physics experiments are performed. This is necessary to support certification of performance and safety of the UK deterrent.

www.awe.co.uk

The Neutron Time-of-Flight (nToF) system measures the neutron energy spectrum generated during laser/plasma interactions, for yields between 2×10^7 and 10^{11} neutrons. The nToF system works in a harsh environment of energetic neutrons, X-rays, gamma rays, and high Electromagnetic Pulse (EMP) noise.

The nToF diagnostic consists of three separate detectors with different scintillator configurations in order to cover the range of possible neutron yields. Neutrons are captured in the scintillator and converted to visible light which is guided into a Photomultiplier Tube (PMT) that converts the optical signal into an electrical one. The electrical signal is transmitted to and displayed

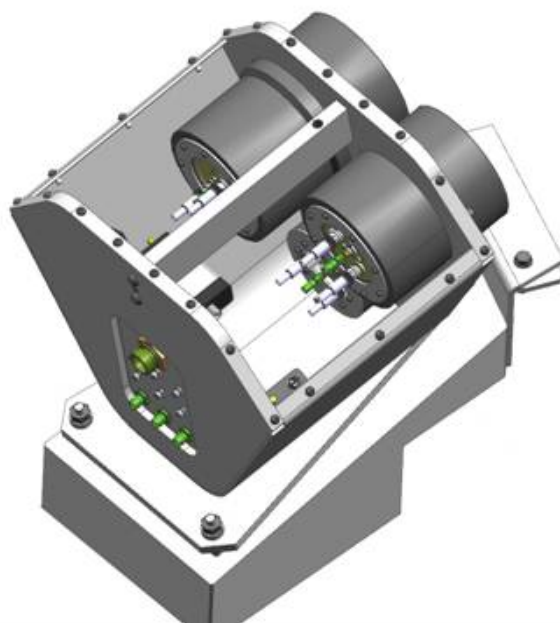

Specification

TIM based

Spectral range: 1-40 nm

Spectral resolution: ~1000

Diffraction gratings: 1-10 nm and 10-40 nm

on an oscilloscope. The Full Width Half Maximum (FWHM) of the signal is used to infer the ion temperature and the area under the peak is used to infer Total Neutron Yield (TNY).

The nToF diagnostic is located outside the Target Chamber 5.6m from the target, providing a means of discriminating neutrons of different energies through their time of flight. Time resolving the arrival of the neutrons allows you to get an accurate spectrum of the neutron energies. A 5.6 m flight path is adequate for ion-temperature measurements.